

PROTECT VENTSORB® 70R Sales Specifications – Regenerable



VENTSORB® 70R

DESCRIPTION

The **VENTSORB® 70R** is an activated carbon adsorber designed to treat air streams containing hydrogen sulphide (H₂S) and other odorous compounds.

The **VENTSORB® 70R** uses the patented **CENTAUR® HSV** catalytic non-impregnated carbon which can be regenerated in-situ with water to extend the bed life of the activated carbon before replacement.

Hydrogen Sulphide and mercaptan are converted into water washable sulphuric acid and sulphonic acid respectively, while other contaminants are adsorbed. The **VENTSORB® 70R** comes complete with pipework and fittings to allow water regeneration of the unit.

The air or gas flows through the unit in an upflow direction and the unit is normally utilised as the end of pipe. The outlet should be monitored periodically to check the activated carbon is achieving the treatment objective. For larger flows or duties, a number of units can be used in parallel.

FEATURES

- Longer bed life through in-situ regeneration of the activated carbon.
- Continuous treatment at varying flow rates and concentrations
- Simple installation and operation
- Corrosion resistant materials

CARBON TYPE FOR ODOUR CONTROL

Compounds	Recommended Carbon Type	Quantity Kg
H ₂ S and Mercaptans	CENTAUR® HSV	102

See specific carbon bulletin for additional information, including the bulletin 'Regeneration procedure for **CENTAUR® HSV**

REGENERABLE OPTION

With **Chemviron Carbon's** patented **CENTAUR® HSV**, a regenerable option is available which has additional connections to allow regeneration of the unit with water.

CENTAUR® HSV is a high activity non-impregnated activated carbon designed specifically for its improved properties in odour removal from sewage treatment applications. This patented product is unique in that it provides a high capacity for H₂S removal without requiring chemical impregnates.

CENTAUR® HSV has enhanced catalytic properties, which promote a fast reaction between the odorous sulphur compounds and oxygen present in the air. H₂S and mercaptans are converted respectively into water washable sulphuric acid and sulphonic acid, while the other contaminants are readily adsorbed

PACKAGING

The empty unit and carbon are supplied separately. This is to allow easy handling. The carbon is normally supplied in a fibre drum.

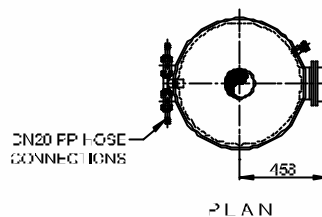
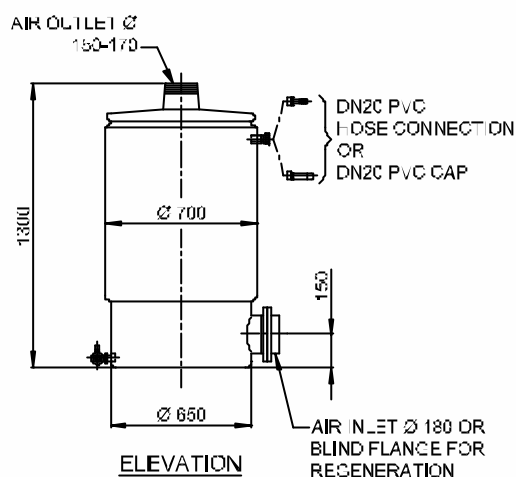

TECHNICAL DESCRIPTION

Carbon volume per adsorber	280 l max.
Flow rate, maximum	600 m ³ /h
Temperature, maximum	65°C
Pressure, maximum ¹	0.04 bar (gauge) or 4 kPa
Diameter adsorber	700 mm
Straight side adsorber	740 mm
Connection – gas inlet	DN180 with flange for blinding
Connection – gas outlet	150 – 170 mm ribbed tapered nozzle
Bottom Connection – water inlet and drain	2 x DN20 PP hose connector with valve
Top overflow assembly – Closed end or liquid outlet	DN20 PVC cap or DN20 PVC hose connection
Vessel and pipe materials	All H ₂ SO ₄ resistant (PE, PP and PVC)
Distributor	Flat internal support, polypropylene mesh
Water flow rate - upflow	100 liter/hour
Footprint	0.8 x 0.8 m
Height – upright	1.41 m
Recommended clearance	1.7 m
Shipping Weight	Empty adsorber: 21 kg Carbon: 112 kg
Weight – operating	Adsorption 200 kg Regeneration 380 kg

¹ The unit is not vacuum rated, can stand only 2 kPa vacuum.

SAFETY MESSAGE

Wet activated carbon preferentially removes oxygen from air. In closed or partially closed containers and vessels, oxygen depletion may reach hazardous levels. If workers are to enter a vessel containing carbon, appropriate sampling and work procedures for potentially low-oxygen spaces should be followed.

QUALITY

Each of our worldwide operations has achieved ISO9001 certification for their quality management system related to activated carbon. **Chemviron Carbon** guarantees the specifications against representative sampling.

PRESSURE DROP

Typical Pressure Drop of
VENTSORB® 70R - CENTAUR® HSV

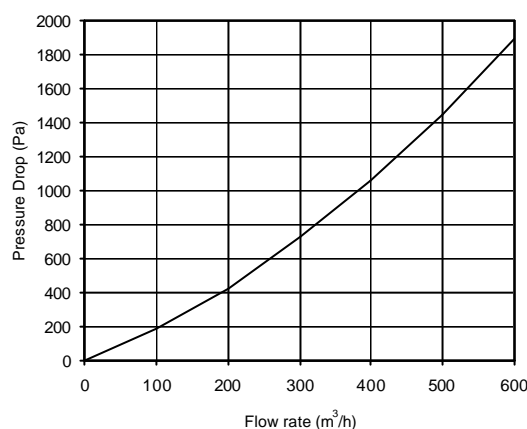

CHEMVIRON CARBON

Chemviron Carbon, the European operation of Calgon Carbon Corporation, is a global manufacturer, supplier, and developer of granular activated carbon, innovative treatment systems, value added technologies, and services for optimizing production processes and safely purifying the environment.

With our experience developed since the early years of the twentieth century, facilities around the world and a world-class team of over 1,200 employees, Calgon Carbon Corporation can provide the solutions to your most difficult purification challenges.

N.B. Chemviron Carbon reserves the right to change specifications without notice. All rights reserved for reproduction in part or in full without prior permission from Chemviron Carbon.

Visit our website at www.chemvironcarbon.com

ES-1190 -E - 18.07.2006



Corporate Headquarters
400 Calgon Carbon Drive
Pittsburgh, PA 15205, USA
Tel.: +1 (0) 412 787-6700
Fax: +1 (0) 412 787-6713



European Operations of
Calgon Carbon Corporation
Zoning Industriel C de Feluy
B - 7181 Feluy, Belgium
Tél.: +32 (0) 64 51 18 11
Fax: +32 (0) 64 54 15 91

Your local office

